

THIS DRAWING IS UNPUBLISHED. RELEASED FOR PUBLICATION  
 © COPYRIGHT BY TYCO ELECTRONICS CORPORATION. ALL RIGHTS RESERVED.

LOC	DIST	REVISIONS			
P	LTR	DESCRIPTION	DATE	DWN	APVD
AJ	16	A	REVISED PER OS14-0150-05	11NOV2005	REH JL

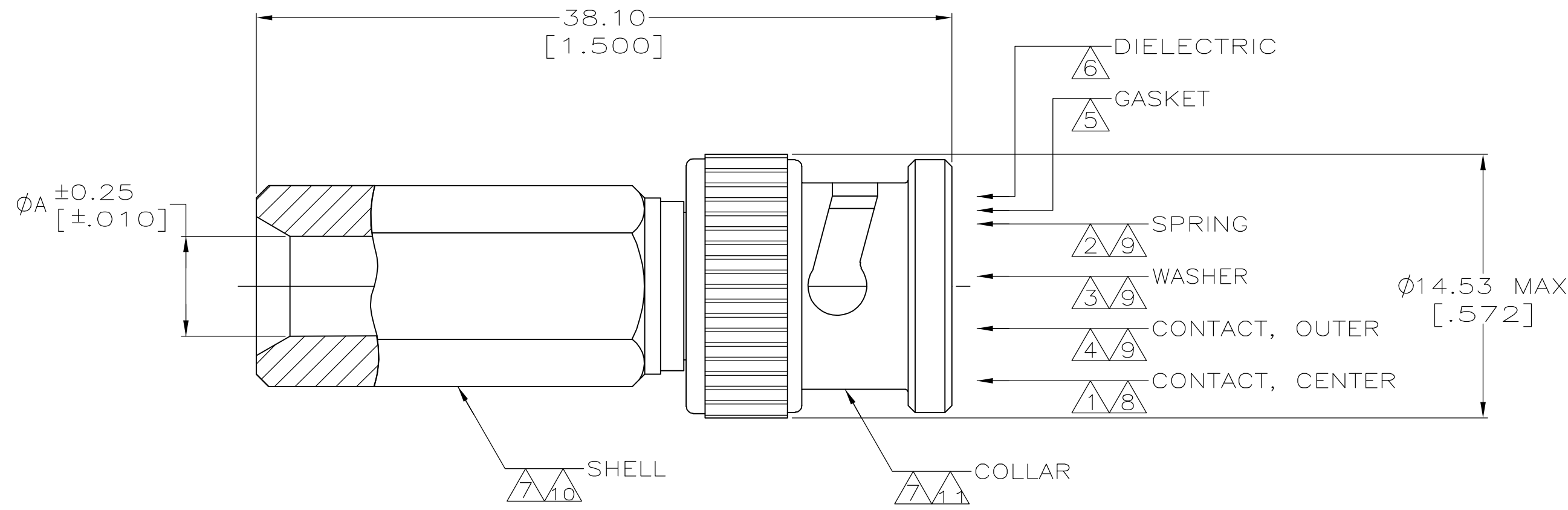

- 1 PHOSPHOR BRONZE PER ASTM-B-139
- 2 CARBON STEEL
- 3 BRASS PER MIL-C-50
- 4 BRASS PER QQ-B-626
- 5 SILICONE RUBBER PER ZZ-R-765
- 6 POLYMETHYLPENTENE: GENERAL PURPOSE
- 7 ZINC DIE CAST PER QQ-Z-363
- 8 GOLD PLATING PER ASTM-B-488  
0.38µm [.000015] MIN THICKNESS
- 9 NICKEL PLATING PER QQ-N-290  
2.54µm [.000100] MIN THICKNESS
- 10 NICKEL PLATING PER QQ-N-290  
3.81µm [.000150] MIN THICKNESS
- 11 NICKEL PLATING PER QQ-N-290  
4.45µm [.000175] MIN THICKNESS
- 12. USE INSTRUCTION SHEET 408-6996

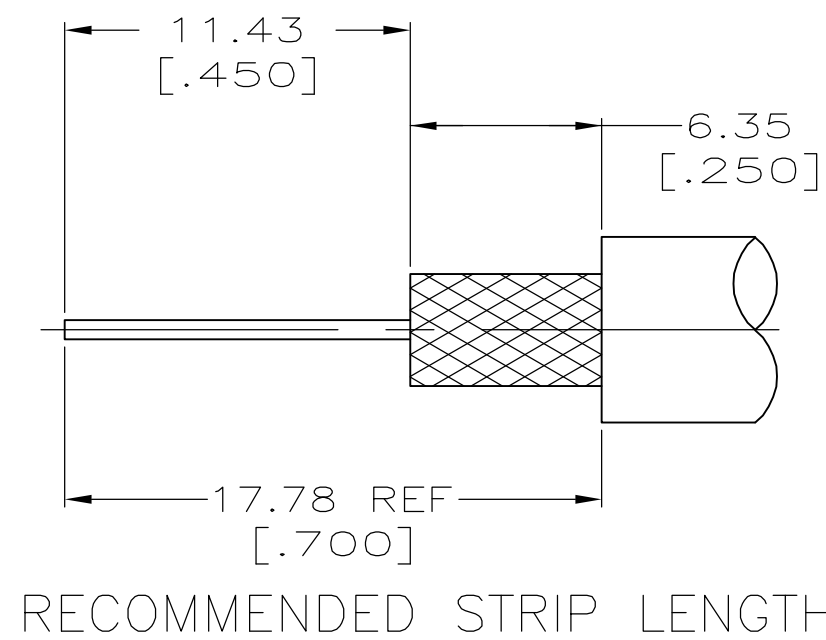

RG-59/U	5.49 [.216]	5414265-3
CABLE	A	PART NUMBER

THIS DRAWING IS A CONTROLLED DOCUMENT.		DWN J. HAVENER 02NOV2005	Tyco Electronics Corporation Harrisburg, PA 17105-3608				
DIMENSIONS: mm [INCHES]		CHK J. HAVENER 02NOV2005					
TOLERANCES UNLESS OTHERWISE SPECIFIED:		APVD J. LIPPERT 02NOV2005	NAME PLUG ASSEMBLY, 50 OHM, TWIST-ON, BNC				
0 PLC ± - 1 PLC ± - 2 PLC ± 0.51 [.020] 3 PLC ± - 4 PLC ± - ANGLES ± - FINISH SEE NOTES		PRODUCT SPEC APPLICATION SPEC	SIZE A2	CAGE CODE 00779	DRAWING NO C=5414265	RESTRICTED TO	
MATERIAL SEE NOTES		WEIGHT -	CUSTOMER DRAWING		SCALE 4:1	SHEET 1 of 1	REV A